



WHITE PAPER
P3™ DLP

Low Volumes Made Affordable

Proven Performance
of a High Precision
3D Printing System





Introduction

3D printing or additive manufacturing, is an economically viable method for producing low volume series. It eliminates the need for tooling, which is expensive and comes with long lead times. While many 3D printing systems have made significant advancements in meeting production requirements, achieving the highest levels of accuracy and repeatability has remained a challenge.

With the new Origin® solution, manufacturers now have an alternative to high volume production that can meet their most stringent requirements which simply was not possible with additive before. This white paper substantiates the capabilities of the platform as a production-ready solution.

As additive applications journey towards production, quantifying process capabilities becomes more important. For end-use production parts, precision assessments and control processes must be robust.

Here we report on an in-depth analysis of the accuracy and repeatability capabilities of the Origin® Two printer. The study highlights Origin® Two's ability to consistently deliver precise, high-quality parts, across multiple machines, prints, geometries, materials and build platforms.





Conclusions

This study characterizes the results of 258 printed parts and 15,999 measurements, across three printers, six build heads, two materials and two-part geometries:

- 1) A Generic Connector part, printed in Loctite 3955™ FST
- 2) A Test Object, printed in Loctite 3843™ Black.

Parts were carefully measured with an optical scanner and a 3D scanner. We evaluated results both across printers and within printers.

Our results show that the precision process capabilities of the Origin® Two and Origin Cure™ are on par with standard injection molding tolerances and are suitable for the industrial production of polymer parts. 95.0% of the Generic Connector's hole diameters were measured within 50µm of their mean and 99.7% of all measured features were within 100µm of their mean. 3-sigma values (99.7% of measurements within) averaged 0.067 mm across prints, printers, and build heads. For reference, the typical standard injection molding tolerance for 1-20mm features for 30% glass-filled Nylon is 60um, and 120um for 21-100mm features.

Across all measurements of the Test Object, 91.3% of all measured features were within 50µm of their mean and 100% of all measured features were within 100µm of their mean. Test Object 3-sigma values averaged 97µm across all measured features/sizes and prints. For reference, the typical standard injection molding tolerance for 1-20mm features for ABS is 100µm and 150um for 21-100mm features.

Together, this data demonstrates that the Origin® Two printer in combination with the Origin Cure™ post-cure unit, can consistently produce high-quality parts with a high degree of repeatability across different printers, builds, and platform locations. The full solution can meet the requirements of those seeking to produce consistent, functional, end-use polymer parts at scale.

Industrial manufacturing equipment and processes must be trusted to deliver consistent results to find a place in production manufacturing. It was the intention of this study to test the system under conditions that represented those that a user will experience for operations in a production environment. We encourage the reader to review the data summaries and visualizations in this document for full details.

These will substantiate the accuracy and precision that is achievable on the Origin® Two printer with the Origin Cure™ post-cure unit.

3D Printing for Production Requires Accuracy and Repeatability

3D Printing has been prized for prototyping since its inception. In recent years, users are progressing towards additive production use cases – manufacturing functional, end-use parts at scale – as an affordable alternative to traditional high-volume manufacturing.

The requirements of a manufacturing process in a production environment differ from those of prototyping. Production requires a 3D printing solution/workflow that is accurate when it comes to the geometric dimensions and material properties of manufactured parts. And the accurate results must be repeatable, within print and across prints and printers.

The full solution for additive production of accurate and repeatable end-use parts does not end with the printer. The full workflow, from print preparation to post-processing must be considered, Standard Operating Procedures (SOPs) must be followed, and the appropriate equipment should be used. Stratasys publishes P3™ DLP material processing guides that detail the equipment, processes, and the end-to-end workflow for each material. Material processing guides detail the holistic workflow to produce quality parts for each validated material: print preparation processes and suggestions, cleaning and drying procedures, and the post-cure program.

Using the specified equipment and SOPs, combined with an in-control process yields predictable variance and results in an improved yield, a stable manufacturing operation, and the best possible part quality.

Additive manufacturing comes in many varieties. Origin® Two, powered by P3™ technology, projects a UV DLP image to selectively cure a photopolymer resin. Combined with P3's separation mechanism and the Origin Cure™ post-processing system, it produces highly precise parts and features. How precise? Read on to find out more.



Accuracy and Precision

Accuracy, precision (aka repeatability), and consistency are three related terms but are not synonymous. Accuracy and precision may be used interchangeably in colloquial conversation but in an engineering context they are distinct.

Accuracy indicates how dimensionally close a single printed part is to the dimensions of the CAD file it was printed from. Accuracy reflects the correctness of a single printed part and doesn't consider repeatability.

Precision refers to the variability from producing many parts under unchanged conditions, and how similar (or varied) the dimensions are. Precision can be thought of as the "spread" of the data. This document evaluates the dimensional accuracy and precision of printed parts and features within them. We use "precision" and "repeatability" interchangeably in this document.

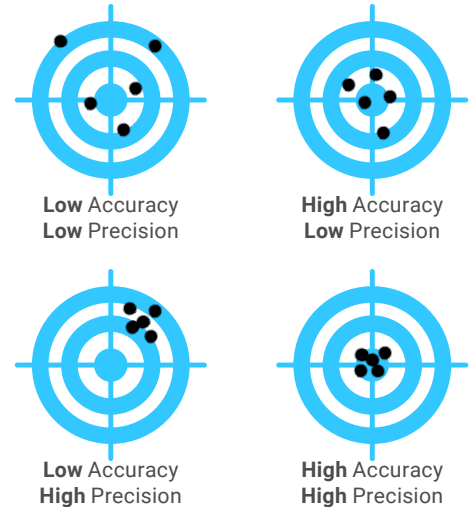

Inaccuracies are compensable with an adequately precise process and software compensation techniques available with Origin® Two and GrabCAD Print™. Repeatability/precision is a system limitation/capability and defines the tolerances that can be specified. Therefore, the repeatability capability of a system is the primary concern for customers who are producing functional parts at scale.

We recognize the importance of consistent dimensional accuracy, and various other aspects of part quality, to enable additive production. We also value proof. As such, we present here a study outlining the dimensional accuracy and repeatability performance of Origin® Two.

Dimensional accuracy is critical to most applications, but a process with good dimensional precision can compensate for dimensional inaccuracies with software techniques. On the contrary, repeatability/precision is a limitation/capability of a system and defines the tolerances that can be specified. As such, repeatability is the most important concern for customers producing functional end-use parts in scale manufacturing.





Methodology

The test methodology for this study examines the variability of our additive process by collecting quantitative measurement data through various dimensional inspections and analyzing the resulting data with various statistical techniques.

Average error and standard deviations of feature dimensions are standard measures of accuracy and precision, respectively, and are reported as such. We also calculated and measured maximum and minimum values, ranges, coefficients of variation, and the 2-, 3-, and 6-sigma values.

All parts were printed with default standard settings for each material and processed with the standard Stratasys workflow as outlined in the material processing guides: print settings, printer/material preparation, part removal, cleaning, and post-curing. There was no additional part finessing or finishing. We utilized GrabCAD's "Z compensation" software feature to correct for initial Z inaccuracy and filtered 16 data points that were erroneously captured by the optical scanner.

Post-print, parts were cleaned in isopropyl alcohol (IPA) sonication baths for two 2-minute cycles, followed by compressed air drying and 60 minutes of further drying in the controlled lab environment. After drying, all parts were post-cured in the Origin Cure™ post-cure unit with the appropriate program for each material.

The Test Object parts were cleaned in sonicated isopropyl alcohol and post-cured in the Origin Cure, and the Generic Connectors were cleaned in Loctite® Cleaner T and post-cured in a programmable thermal oven according to the Stratasys Material Processing Guides. After cleaning, parts were dried using compressed air followed by 60 minutes of further drying in the controlled lab environment. After drying, all parts were post-cured in the Origin Cure post-cure unit with the appropriate program for each material.

Printing, post-processing, conditioning, inspection and measurements were all performed in a well-ventilated, temperature and humidity-controlled lab environment. All measurements were taken between 24 and 48 hours after post-cure.

In this document, we report multiple statistical metrics.

They are defined as follows:

- **Mean (aka average):** The sum of the measurements, divided by the number of measurements.
- **Maximum:** The biggest measured value.
- **Minimum:** The smallest measured value.
- **Median:** The middle point in the data set, half the measurements are bigger, and half smaller.
- **Range:** The maximum measured value minus the minimum measured value.
- **Standard deviation (aka σ):** The dispersion of the data set relative to the mean. In a normal distribution, 68% of points fall within $\pm \sigma$.
- **2 sigma (aka 2σ):** Twice the standard deviation. In a normal distribution, 95% of points fall within $\pm 2\sigma$.
- **3 sigma (aka 3σ):** Three times the standard deviation. In a normal distribution, 99.7% of points fall within $\pm 3\sigma$.
- **6 sigma (aka 6σ):** Six times the standard deviation. In a normal distribution, 99.9997% of measurements fall within $\pm 6\sigma$.

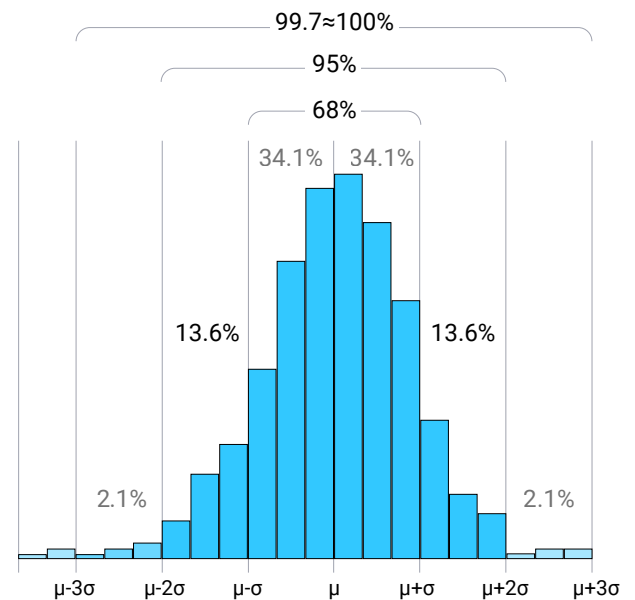

In addition to the measurements defined above, we also report the percentage of measured parts that fall within three tolerance values ($35\mu\text{m}$, $50\mu\text{m}$, and $100\mu\text{m}$). This is useful because it defines the yield for the chosen tolerance. We will report these values within and across printers.



Parts

We printed and evaluated two-part geometries:

- A Generic Connector part, printed in Loctite 3955™ FST
- A Test Object, printed in Loctite 3843™ Black.

Each geometry was printed in a separate print job. Ten Connectors and eight Test Objects were in each geometry's print job. Each print job was printed twice, on three printers, on three different build heads. 210 Total Generic Connector parts were printed and inspected. The Test Object parts were cleaned in sonicated isopropyl alcohol and post-cured in the Origin Cure, and the Generic Connectors were cleaned in Loctite® Cleaner T and post-cured in a programmable thermal oven according to the Stratasys material processing guides.

Generic Connector

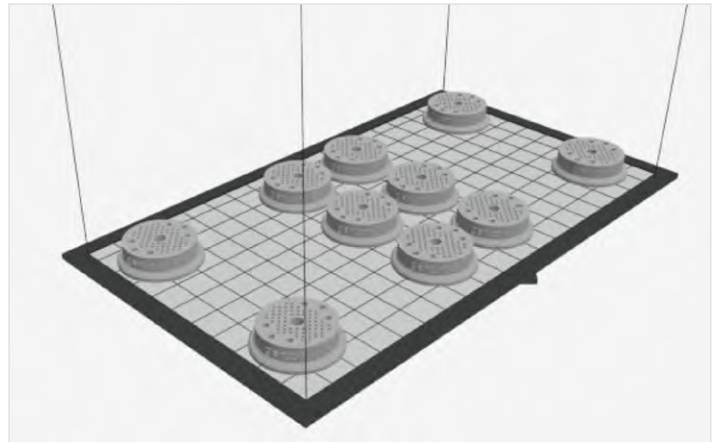
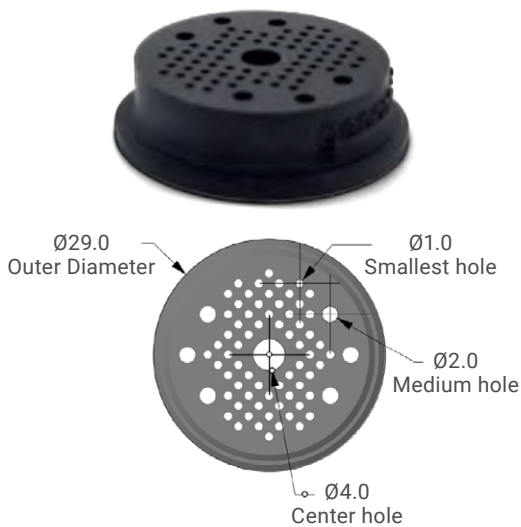

Test Object

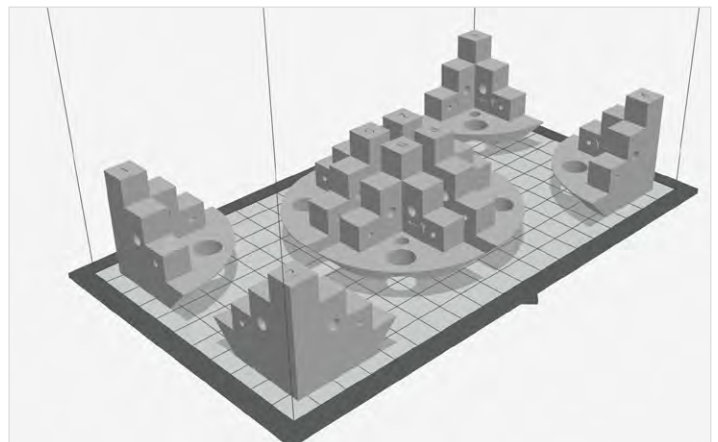

Each part serves a different purpose, and is inspected in different ways:

- The Generic Connector is representative of a real-world functional end-use part application and is printed in a functional material (Loctite 3D 3955™). This part was inspected with a Keyence IM series optical scanner. We measured the 29mm outer diameter (OD) and the diameters of each hole (1, 2, and 4mm). Each part is 3.6cc.
- The Test Object contains various features to evaluate accuracy and precision across a range of geometries. This part was inspected with the Keyence IM scanner and a GOM 3D scanner. The GOM data compared the resulting point cloud against the overlaid CAD file with the scanner software at 10 different locations on the part. Each part is 17.5cc and 39.5 x 39.5 x 40mm.



Limitations

All studies have limitations, including this one. Here we describe some of the limitations we see of our study.

Geometry: For this study, we printed and measured three different part geometries, each designed to evaluate specific features and system precision capabilities. A limited number of parts and features are studied. We know from experience that accuracy and repeatability are highly geometry-dependent, so the results described below may not be applicable to all geometries. The Generic Connector part was designed to emulate a typical electric connector but does not contain all the geometries typical to the widely varying space of additive geometry. The Test Object part contains multiple sized features, but its biggest feature is 40mm.

Material: We know from experience that accuracy and precision are not only geometry-dependent but material-dependent as well. We investigated two materials in this study and results will likely differ with other materials. This study was not intended to look at the effects of resin batch or age on accuracy and repeatability. All resin used for this study was manufactured by Stratasys material partner Henkel Loctite®. Resin used for this study was not specially prepared, bottles were selected from commercially available off-the-shelf inventory. All resin was unexpired, and each bottle was consumed within one week of opening.

Print process: These parts were all printed at the Stratasys HQ in Rehovot, Israel by Stratasys engineers under appropriately controlled lab conditions on Origin® Two printers running standard firmware. Loctite 3843™ parts were cleaned with a Branson Ultrasonic cleaner in IPA and post-cured in the Origin Cure™. Loctite 3955 parts were cleaned with a Branson Ultrasonic cleaner in Loctite Cleaner T. All print jobs were prepared with GrabCAD Print™. We suggest operating Origin® printers and post-processing in a well-ventilated controlled lab environment. Deviating from standard conditions may have an impact on part accuracy and repeatability and result in other part quality issues.

Sample size: Ideally, we would have tested every printer and every build platform with many more prints and many parts per print. We printed three printers and three build platforms for each printer. We invite our customers to replicate our results on their own Origin® Two.

Data and analysis: Data for this study was collected on a PC with the inspection equipment specified in the “Parts” section above. The data analysis that informs this study was completed in Microsoft Excel. Standard statistical methods and calculations were used. There may be advanced or alternative statistical methods to evaluate our data. It is our hope that the data presented here will answer many starting questions regarding the accuracy and precision capability of the Origin® Two and Origin Cure™ system.

Unknowns: There are likely other limitations unforeseen by us. A robust and rigorous study is our intention, but errors are possible. It is our plan and hope for this study to be representative of the performance of future printers, but this will need to be continuously studied. Throughout printer manufacturing, we will evaluate the accuracy and print quality performance of every printer that comes off the Stratasys production line. We will use this data to confirm printer conformance and to inform future studies that will look deeper into the accuracy and repeatability performance across a greater number of printers.





Detailed Results

Below is the full list of the two parts with the measurements:

Generic Connector

- Statistical metrics
 - 1-4mm diameter holes
 - 1mm diameter holes
 - 2mm diameter holes
 - 4mm diameter holes
 - 29mm outer diameter (OD)
- Points within x% of mean
 - 1-4mm diameter holes
 - 1mm diameter holes
 - 2mm diameter holes
 - 4mm diameter holes
 - 29mm outer diameter (OD)
- Variability visualizations
 - Across printers
 - Within printers

Test Object

- 3D scan point cloud comparison data
- Statistical metrics
- Variability visualizations

In the Variability Visualization graphs shown below, the X-axis shows the number of measurements while the Y-axis shows the measurement unit in mm.

Generic Connector

All 1-4mm data together (statistical metrics). Keyence optical scanner, 6482 holes measured.

		All Printers	Printer 1	Printer 2	Printer 3
Average of all hole diameters	Avg. range	0.083	0.092	0.055	0.102
	Avg. stdev	0.020	0.014	0.014	0.020
	Avg. 2 sigma	0.041	0.028	0.028	0.041
	Avg. 3 sigma	0.061	0.041	0.042	0.061
	Avg. 6 sigma a	0.123	0.083	0.084	0.122

All 1-4mm diameter data together (values within x% of mean). Keyence optical scanner, 6482 holes measured.

		All Printers	Printer 1	Printer 2	Printer 3
All hole diameters	% within 35µm of mean	95.5%	98.8%	95.5%	92.3%
	% within 50µm of mean	98.9%	100.0%	99.4%	97.4%
	% within 100µm of mean	99.7%	100.0%	99.6%	99.4%

This is a robust data set with n=6,482 diameter measurements in total across many parts and features. Across printers and build heads, a range of about 83µm, a standard deviation of around 20µm, and a 3-sigma value of around 66µm (or better) can be expected for holes in the 1-4mm range.



Conclusion

Across all printers, build heads, prints and feature dimensions, our Generic Connector results indicate a high degree of precision for the 1-, 2-, and 4mm through-holes as printed on Origin® Two. Looking at all hole sizes together, 95.% of measurements were within 50µm of their mean and 99.7% were within 100µm of their mean.

29mm outer diameter (statistical metrics) n=83*

		All Printers	Printer 1	Printer 2	Printer 3
29mm OD	Max	29.100	29.081	29.067	29.100
	Min	28.949	28.950	28.949	28.991
	Mean	29.026	29.015	29.015	29.052
	Avg. error	0.026	0.015	0.015	0.052
	Median	29.028	29.015	29.017	29.060
	Range	0.151	0.131	0.118	0.109
	Stdev	0.036	0.036	0.118	0.030
	2 sigma	0.072	0.071	0.029	0.060
	3 sigma	0.108	0.107	0.059	0.089
	6 sigma	0.216	0.213	0.088	0.179

29mm outer diameter (values within x% of mean) n=83

		All Printers	Printer 1	Printer 2	Printer 3
29mm OD	% within 35µm of mean	72.6%	63.3%	78.6%	76.0%
	% within 50µm of mean	89.4%	83.3%	92.9%	92.0%
	% within 100µm of mean	100.0%	100.0%	100.0%	100.0%

*Note that for the 29mm outer diameter feature, there was only one feature per part, resulting in 83 measurements total. This is lower than the 90 parts that were measured due to erroneous or missing data.

Conclusion

Across all printers build heads, prints and feature dimensions, our Generic Connector results indicate a high degree of precision for the 29 mm outer diameter as printed on Origin® Two. Demonstrating an average error of 26µm (0.026mm) and a range of 151µm, across the 210 measured parts on all printers and build heads, Origin® Two is consistent and reliable.



Variability Visualizations and Within-Printer Data

1mm diameter through-holes

The following graphs visualize the variability of our measurements of the 1mm diameter through-holes on all three printers. The measurements are colored by printer number and include data collected on three build heads on each printer.

1mm Hole Diameter Variability Data n=5916

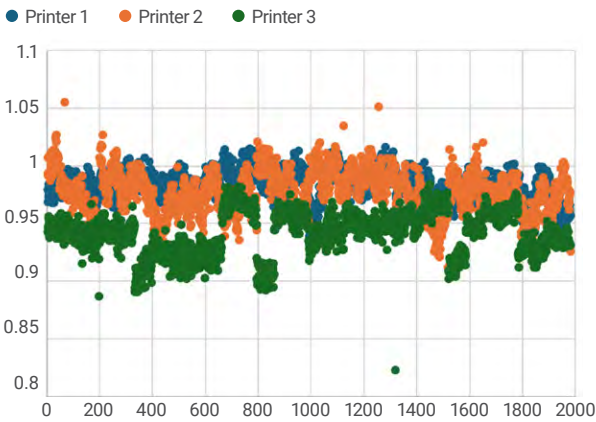

2mm diameter through-holes

The following graphs visualize the variability of our measurements of the 2mm diameter through-holes on all three printers. The measurements are colored by printer number and include data collected on three build heads on each printer.

2mm Diameter Variability Data n=5916

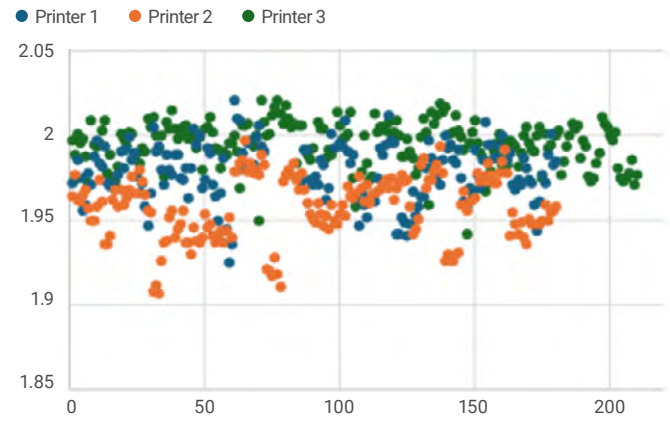

Within any printer, the results are even better. The below table reports the statistical metrics for all prints within each printer. Within any printer, across build platforms, a user can expect an even tighter standard deviation of around 0.011 - 0.016 μm and an even tighter range of around 0.048 - 0.072 μm .

Printer 1
2mm Hole Diameter Variability

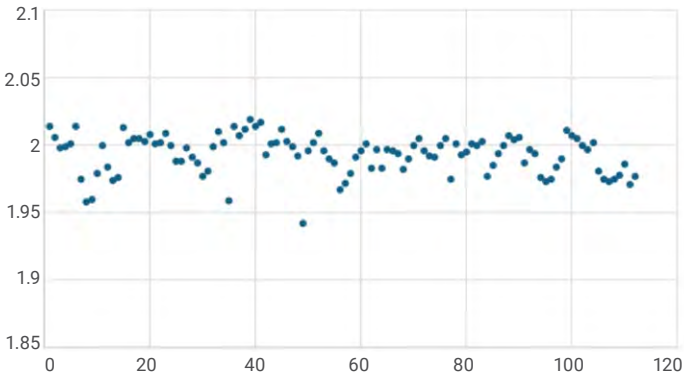

Printer 2
2mm Hole Diameter Variability

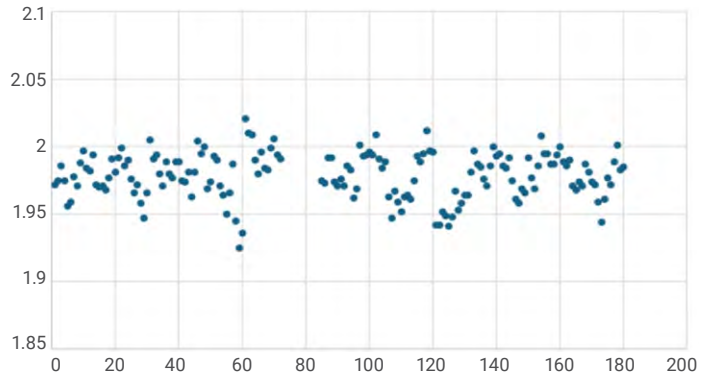

Printer 3
2mm Hole Diameter Variability

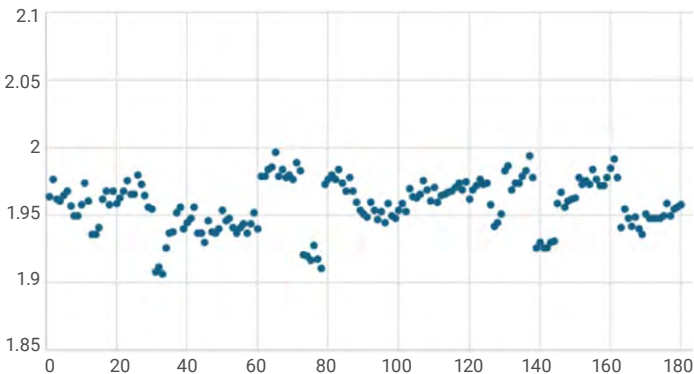



4mm diameter through-holes

The following graphs visualize the variability of our measurements of the 4mm diameter through-holes on all three printers.

The measurements are colored by printer number and include data collected on three build heads on each printer.

4mm Hole Diameter Variability Data n=90

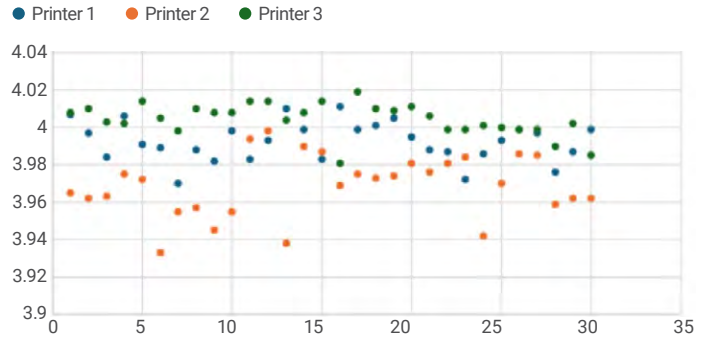

29mm Outer Diameter

The following graphs visualize the variability of our measurements of the 29mm outer diameter on all three printers and build heads.

The measurements are colored by printer number and include data collected on three build heads on each printer.

29mm OD Variability Data n=90

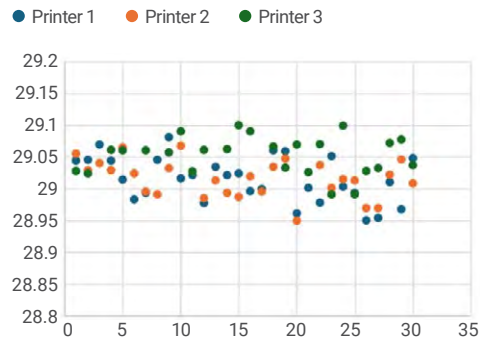

Within any printer, the results are even better. The below table reports the statistical metrics for all prints within each printer. Within any printer, across build platforms, a user can expect an even tighter standard deviation of around 31-36 μ m and an even tighter range of ~ 122-144 μ m.

Within any printer / build head combination, the results are better still. The below table reports the statistical metrics for each printer / build head combination. Within any printer/build platform, a user can expect an even tighter standard deviation of around 26-36 μ m and an even tighter range of around 86-119 μ m.

Generic Connector Conclusion

Our results indicate that with the Origin® Two printer and the Origin Cure™ post-cure system, the P3™ DLP system is capable of meeting robust controlled production precision requirements. Different use cases have different requirements and repeatability is geometry-dependent, so internal validation should be a part of any application qualification process.





Test Object

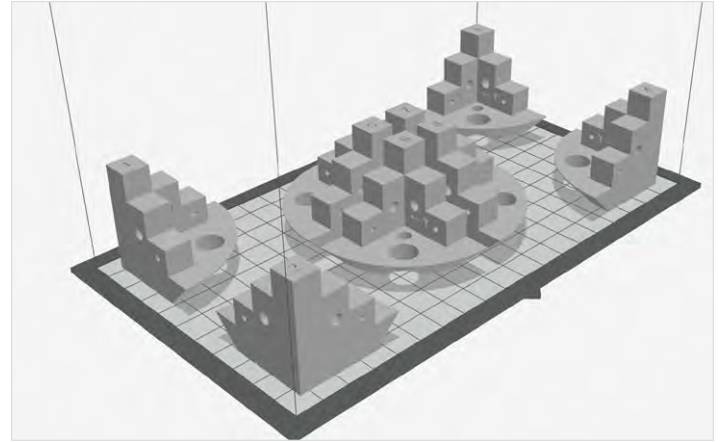
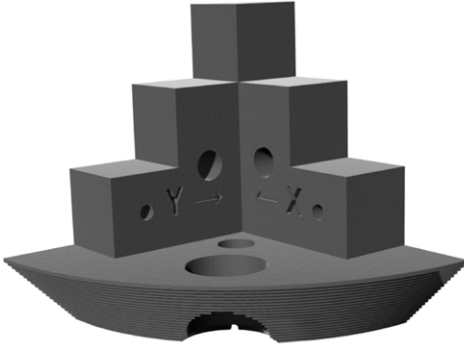

Scan data

We scanned these parts with a GOM 3D scanner and compared the point cloud output with the original CAD data using ATOS Professional software. This scanner data demonstrates the accuracy and repeatability of this part not just on dimensional measurements, but across entire parts and surfaces.

First, we will look at the results of one part, from one print, from one printer (009), on two different build platforms (A and B). Each picture shows the deviation of the scan data from the original CAD data for this part. Each of the 23 boxed numbers shows the deviation at the indicated point.

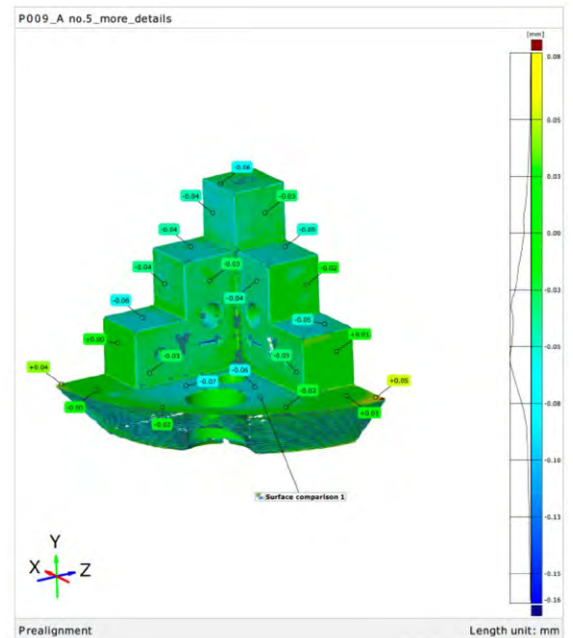

The next picture is a part of the same printer (009), printed on a different build head. While you can see the colors and values have changed slightly, the trends are the same and the magnitude of the deviations are similar.

If we look at two parts from additional printers (190, 574) across two build heads, the results are similar.

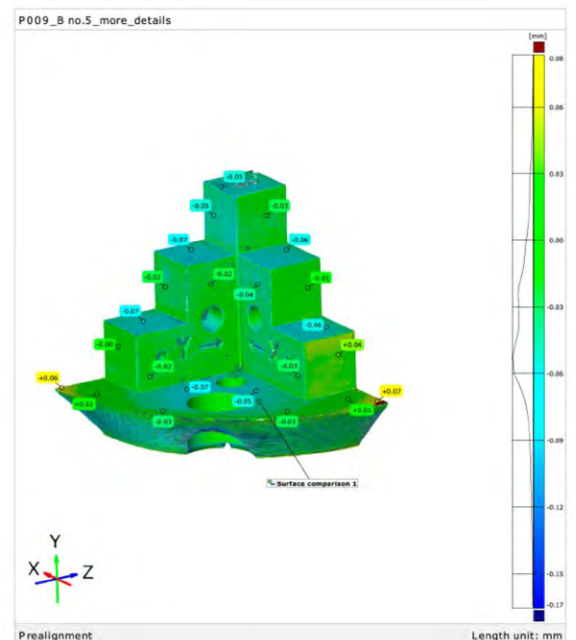

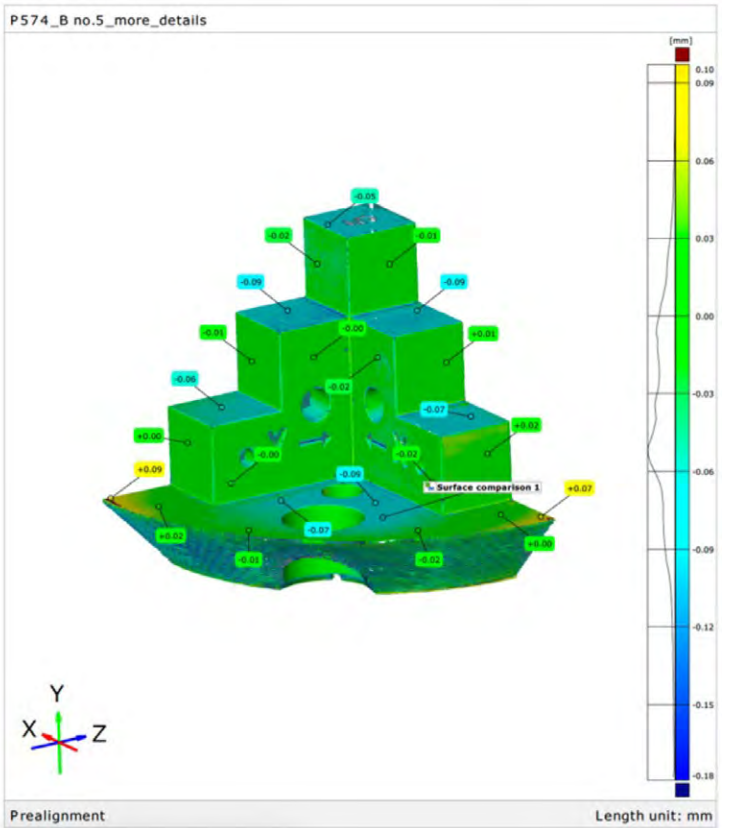
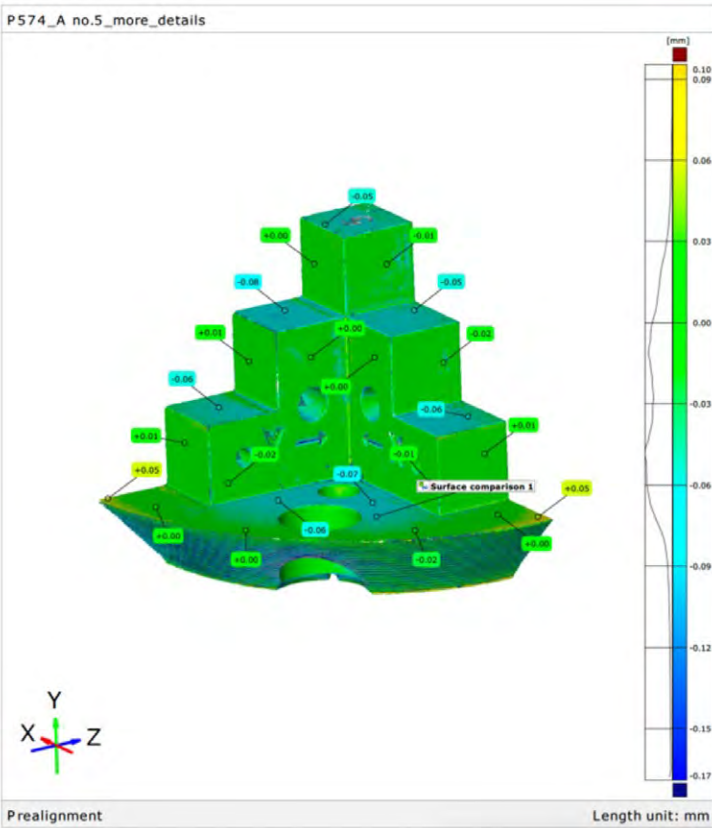
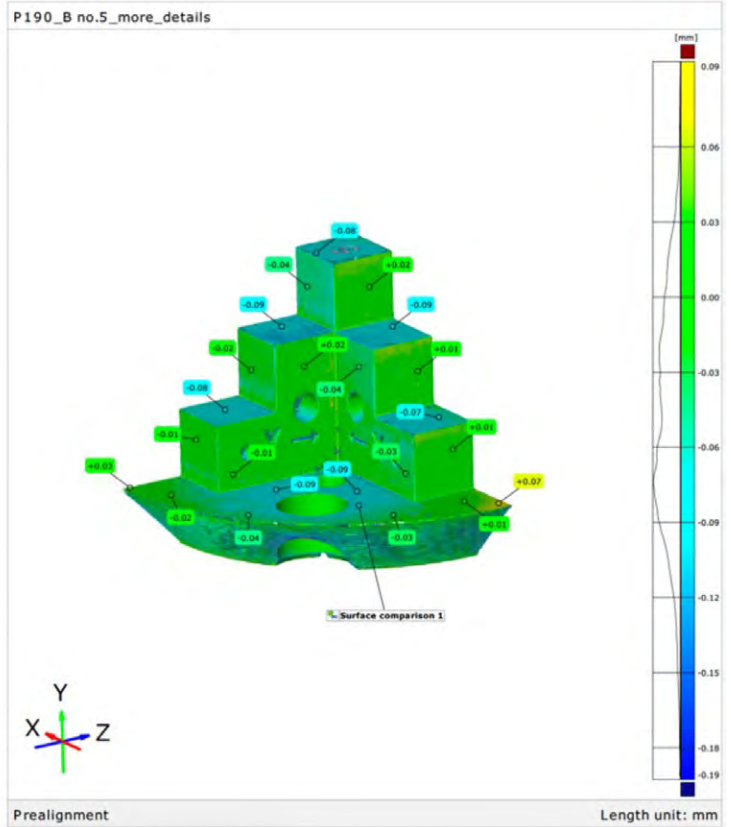
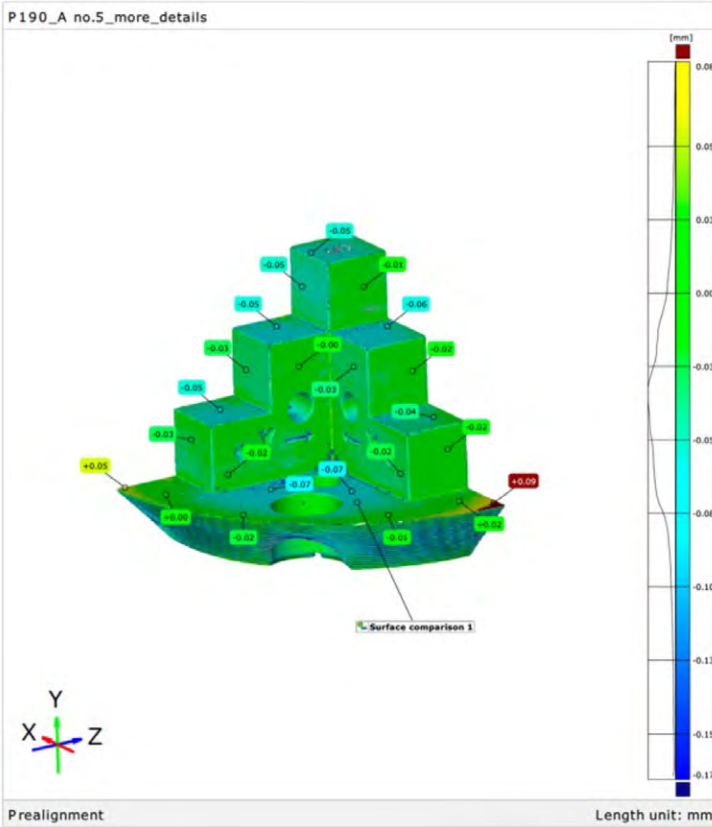

Now we look at the combined results from six parts: two printers, two build head, and one part (part # 5) from each printer/build head. Note that each point on the part now shows a graph with six points and the average deviation and the minimum and maximum deviation for each point. The XYZ value is the specified tolerance (0.1mm). The other values, Pp and Ppk, are process control metrics often used to evaluate system performance in the fields of industrial and/or quality engineering.



Pp is a “performance index”. It measures how well the data might fit between specification limits (USL, LSL). Specification limits are a way to measure tolerance. If a part is specified to be 10mm +/- 0.1mm, the USL would be 10.1mm and the LSL would be 9.9mm. For Pp, the value doesn’t consider how well the process is centered on the nominal dimension, only how well it would fit if it were centered. A Pp above 1.50 is considered acceptable according to the Six Sigma quality engineering philosophy.

Ppk is the “performance centering index”. This value measures how well the data is centered between the specification limits. A Ppk above 1.50 is considered acceptable according to the Six Sigma quality engineering philosophy.

The Ppk values derived from the scan data of all parts range from 1.07 to 4.64. Pp values range from 1.61 to 5.16.

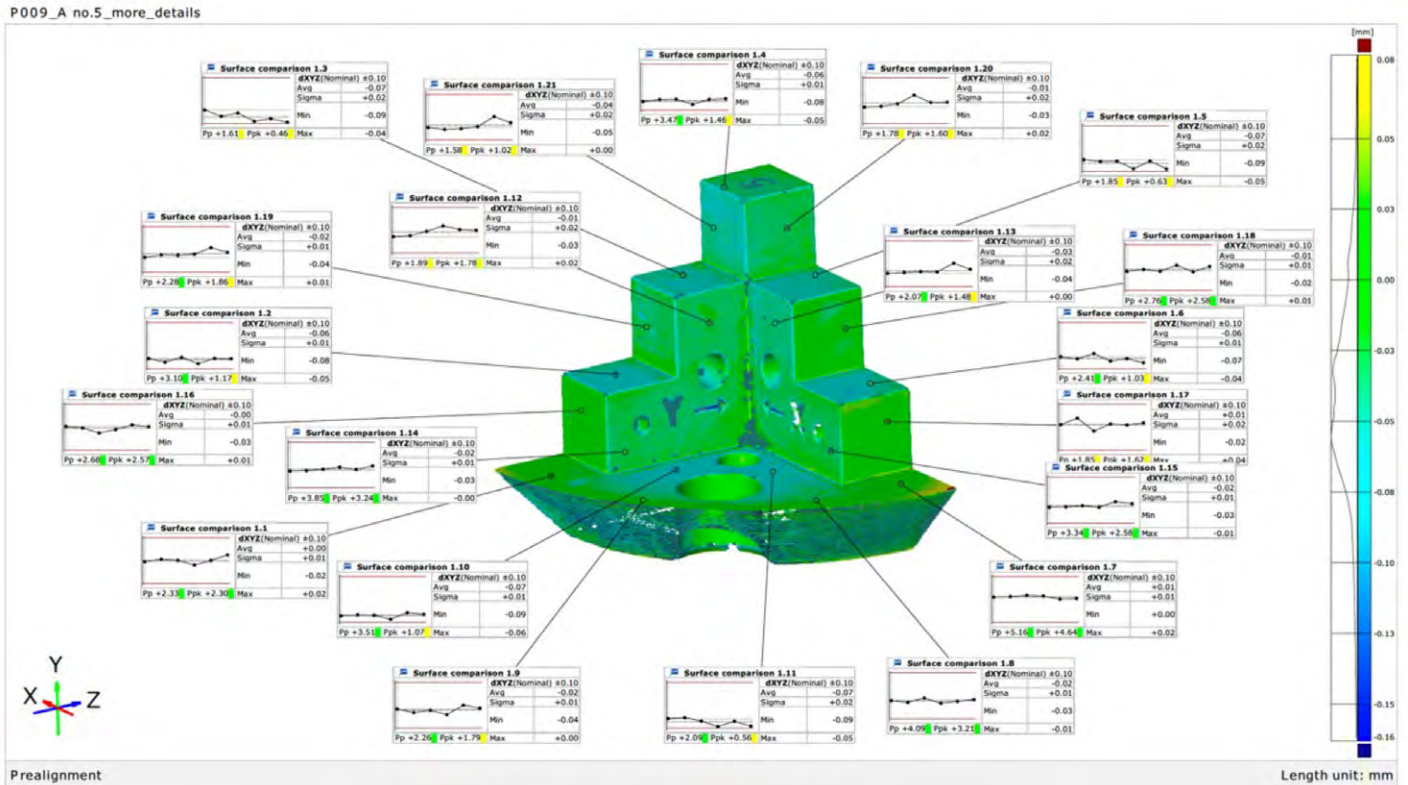

While a picture may equate to a thousand words, pictures alone don’t always tell the whole story; data is usually needed and helpful. For this data, we return to the Keyence optical scanner and will report data on dimensional accuracy and repeatability across prints, printers, build heads, and parts. The first table shows the part scanned lying on each of its two flat sides, “Side X” and “Side Y.” The second table shows the part standing upright. The below data is derived from six prints of eight parts each, totaling 48 parts. Note that each column is for a different feature / nominal dimension.

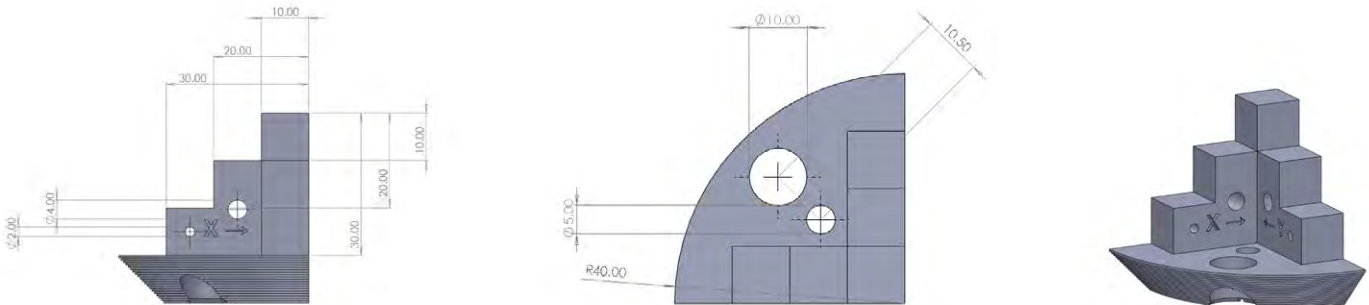

The above Test Object indicates Keyence-measured dimensions.



Across All Printers

The table below reports statistical metrics for all prints on all printers and build heads.

Nominal Dimensions		4	2	10	20	30	40	30	20	10
Side A	Maximum	4.033	2.024	10.046	20.12	30.194	40.079	30.061	20.057	10.135
	Minimum	3.917	1.944	9.959	19.976	29.996	39.916	29.897	19.907	10.017
	Average	3.987	1.986	10.008	20.042	30.086	39.998	29.985	19.987	10.069
	Average error	-0.013	-0.014	0.008	0.042	0.086	-0.002	-0.015	-0.013	0.069
	Range	0.116	0.080	0.087	0.144	0.198	0.163	0.164	0.150	0.118
	Standard deviation	0.020	0.019	0.025	0.037	0.052	0.042	0.041	0.034	0.029
	6 sigma	0.123	0.113	0.148	0.223	0.315	0.254	0.248	0.207	0.172
	3 sigma	0.061	0.057	0.074	0.112	0.157	0.127	0.124	0.103	0.086
	2 sigma	0.041	0.038	0.049	0.074	0.105	0.085	0.083	0.069	0.057

Nominal Dimensions		4	2	10	20	30	40	30	20	10
Side B	Maximum	4.027	2.02	10.137	20.05	30.051	40.073	30.176	20.105	10.065
	Minimum	3.939	1.938	9.977	19.865	29.872	39.906	29.983	19.97	9.951
	Average	3.987	1.984	10.064	19.98	29.979	39.993	30.079	20.037	10.005
	Average error	-0.013	-0.016	0.064	-0.02	-0.021	-0.007	0.079	0.037	0.005
	Range	0.088	0.082	0.16	0.185	0.179	0.167	0.193	0.135	0.114
	Standard deviation	0.021	0.021	0.037	0.041	0.044	0.040	0.046	0.033	0.025
	6 sigma	0.126	0.124	0.220	0.248	0.262	0.239	0.277	0.198	0.149
	3 sigma	0.063	0.062	0.110	0.124	0.131	0.120	0.138	0.099	0.075
	2 sigma	0.042	0.041	0.073	0.083	0.087	0.080	0.092	0.066	0.050

Nominal Dimensions		10	5	10.5	40
Top	Maximum	10.002	5.013	10.534	40.065
	Minimum	9.909	4.907	10.482	39.896
	Average	9.950	4.948	10.511	39.975
	Average error	-0.050	-0.052	0.011	-0.025
	Range	0.093	0.106	0.052	0.169
	Standard deviation	0.021	0.026	0.013	0.042
	6 sigma	0.126	0.154	0.081	0.249
	3 sigma	0.063	0.077	0.040	0.125
	2 sigma	0.042	0.051	0.027	0.083



Nominal Dimensions		4	2	10	20	30	40	30	20	10
Sides A&B All printers	Maximum	4.033	2.024	10.102	20.12	30.194	40.079	30.176	20.105	10.135
	Minimum	3.917	1.938	9.959	19.865	29.872	39.906	29.897	19.907	9.951
	Average	3.985	1.985	10.036	20.011	30.032	39.996	30.032	20.012	10.037
	Average error	-0.046	-0.039	-0.101	-0.109	-0.162	-0.084	-0.144	-0.093	-0.098
	Range	0.116	0.086	0.143	0.255	0.322	0.173	0.279	0.198	0.184
	Standard deviation	0.020	0.019	0.025	0.037	0.052	0.042	0.041	0.034	0.029
	6 sigma	0.123	0.113	0.148	0.223	0.315	0.254	0.248	0.207	0.172
	3 sigma	0.061	0.057	0.074	0.112	0.157	0.127	0.124	0.103	0.086
	2 sigma	0.041	0.038	0.049	0.074	0.105	0.085	0.083	0.069	0.057



Within and Across Printers

Variability plots show the variability within each printer (colors) and across printers (all data points) for various features/sizes. Note the narrowness of the Y axis scale to help understand the range.

Test Object - 4mm Hole Diameter Variability

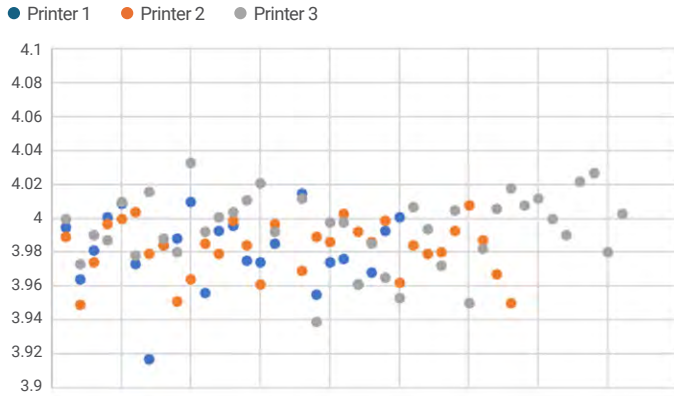

Test Object - 20mm Linear Diameter Variability - Side A and Side B

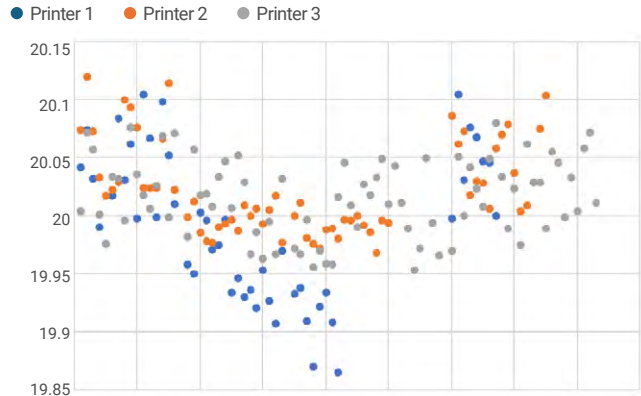

Test Object - 30mm Linear Diameter Variability - Side A and Side B

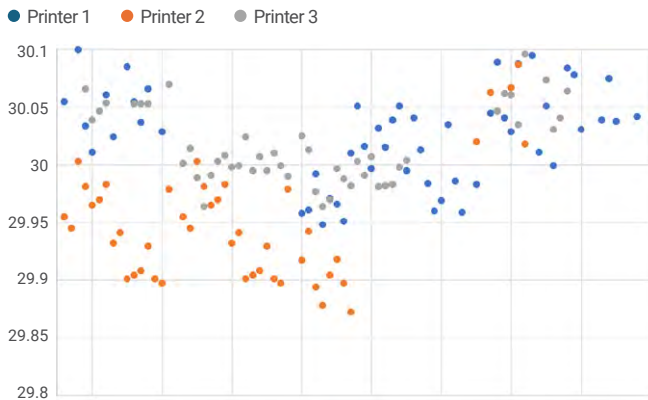

Results compared to injection molding

3D printing polymer parts for industrial production applications is one of our goals and a goal for many Stratasys customers. Traditionally, most of these parts have been injection molded. How do these results stack up against injection molding tolerances? The below table shows standard tolerances for injection molded plastic parts from five different thermoplastics. With both injection molding and DLP printing, stiffer materials can typically achieve tighter tolerances than softer ones.

IM material	Dimension size		
	1 to 20 mm	21 to 100 mm	101 to 160 mm
ABS	0.100	0.150	0.325
PA	0.075	0.160	0.310
PP	0.125	0.170	0.375
HDPE	0.125	0.170	0.375
30% GF PA	0.060	0.108	0.240

Comparing the ABS standard tolerances to the average 3-sigma value for the 3D printed Test Object, the Test Object compares favorably to standard tolerances for injection molding. 3-sigma was chosen (conservatively) because 99.7% of parts should fall within this range, and a typical scrap rate for an injection molding part is typically on the order of 1-5%. Note that not all scrap is due to dimensional inaccuracy, but it is likely that more than 0.3% of parts are dimensionally out of spec for most injection molded parts.



		1 to 20 mm	21 to 100 mm	
Standard Tolerance	IM ABS	0.100	0.150	–
3 sigma avg.	3DP 3843	0.082	0.125	Test object

The results are similar when we compare the Loctite 3955™ Generic Connector 3-sigma average against 30% glass-filled nylon (30% GF PA) standard tolerances.

		1 to 20 mm	21 to 100 mm	
Standard Tolerance	IM 30% GF ABS	0.060	0.120	
3 sigma avg.	3DP 3955	0.066	0.108	Generic connector

It's worthwhile restating some study limitations. This study considers two parts in two materials, and we know results vary by geometry and material. Additive manufacturing is a nascent industry compared to the 150-year history of injection molding, and achieving accuracy and repeatability parity is a journey. We encourage further study and publication regarding the results our customers achieve with Origin® Two and Origin Cure™ on their own geometries.



ISO 9001:2015
Certified

PURPLE PLATYPUS
ADVANCED 3D SOLUTIONS

PHONE
949.474.9222

EMAIL
ask@purpleplatypus.com

VISIT
16842 Hale Ave.
Irvine, CA 92606

WHITE PAPER
P3™ DLP

© 2024 Stratasys. All rights reserved. Stratasys, the Stratasys Signet logo, Origin, Origin Cure, P3 and GrabCAD Print are registered trademarks of Stratasys Inc. All other trademarks are the property of their respective owners, and Stratasys assumes no responsibility with regard to the selection, performance, or use of these non-Stratasys products. Product specifications are subject to change without notice. WP_P3_Production Accuracy Repeatability_0824a